

JOHN FIG. 245 High Pressure Globe Valve

MAX WORKING PRESSURE: Water, Oil, Gas: 6200 kPa @ 232°C
Steam: 3100 kPa @ 425°C

HYDROSTATIC TEST PRESSURE:
Body: 9300 kPa
Seat: 6820 kPa

The John/Dreadnought 245 is a forged carbon steel globe valve. The 245 is suitable for high pressure and/or high temperature service. Standard 245's are flanged to AS2129 Table 'K' - undrilled, and can be drilled to customer specifications. Other connection options are available upon request, i.e. buttweld.

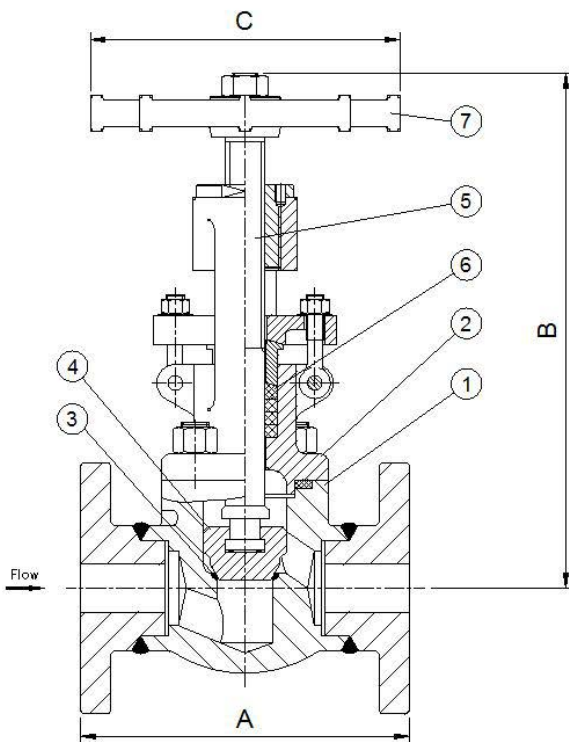

MATERIALS OF CONSTRUCTION

ITEM	DESCRIPTION	MATERIAL	STANDARD
1.	BODY	FORGED STEEL	ASTM A105
2.	BONNET	FORGED STEEL	ASTM A105
3.	SEAT	13% CHR STELLITE	AISI 410 SS
4.	DISC	13% CHR SS	AISI 420 SS
5.	STEM	STAINLESS STEEL	AISI 416 SS
6.	PACKING	GRAPHITE	
7.	HANDWHEEL	CARBON STEEL	

DIMENSIONS

SIZE	A	B (OPEN)	C	wt. (kg)
15	143	170	76	4
20	159	185	76	5.5
25	178	210	98	7
32	191	270	139	12.5
40	216	270	139	13
50	241	305	139	18