

# JOHN FIG. 771 & 772 Air Valve

This design of air valve for use in water systems to allow automatic ventilation of the pipeline during filling and emptying. When filling, air is exhausted at a sufficiently high capacity to prevent restriction of the filling rate due to built up back up back pressure. When emptying, air is admitted to the pipeline at a rate sufficient to prevent high vacuum pressures developing.

## Operation

Under normal operating conditions, the ball is held on the seat by pipeline pressure and drops to atmospheric. The ball is closely guided in the body and when the pipeline is filling, is held suspended in the exhaust air flow, away from the seat, by the aerodynamic design of the body. This aerodynamic feature has been the subject of extensive research at our in-plant test facilities and at various field installations to ensure there is no possibility of premature valve closure even with sonic air discharge velocities.

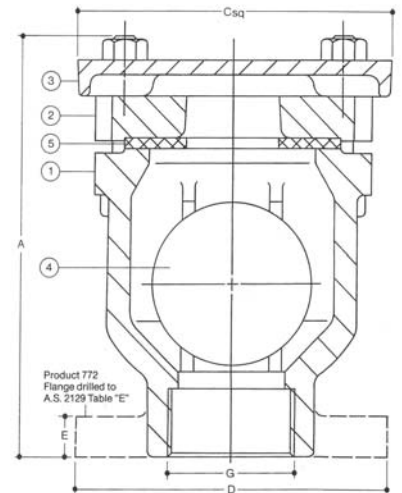

Product No. 771: Screwed B.S.P. Female  
Product No. 772: Flanged to AS2129 Table 'E'

## MATERIALS OF CONSTRUCTION

ITEM	DESCRIPTION	MATERIAL
1.	BODY	CAST IRON
2.	COVER	CAST IRON
3.	GUARD	CAST IRON
4.	BALL	RUBBER-CEDAR CORE
5.	BALL SEAT	POLYURETHANE

TABLE OF FLOW COEFFICIENTS	
VALVE SIZE mm	FLOW COEFFICIENTS
25	0.0096
50	0.0296
80	0.0446

## Sizing of large Orifice Air Valves

The air discharge rate through an aerodynamic large orifice valve can be determined from the following approximate expressions:

**A. For pressure drops up to 210 kPa:**

$$Q = C \sqrt{P} \text{ m}^3/\text{sec at S.T.P.}$$

**B. For pressure drops 210 kPa and above:**

Note: The critical pressure ratio on choked flow condition occurs at a pressure differential of 210 kPa wherein the flow rate remains the same as the pressure drop increases.

$$Q = C \sqrt{210} \text{ m}^3/\text{sec at S.T.P.}$$

Where: Q = Volumetric Flow Rate at S.T.P.

(101.3 kPa - 15°C)

P = Pressure Drop Across Valve in kPa.

C = Valve Flow Coefficient (from table)

Discharge Capacities  
LARGE ORIFICE

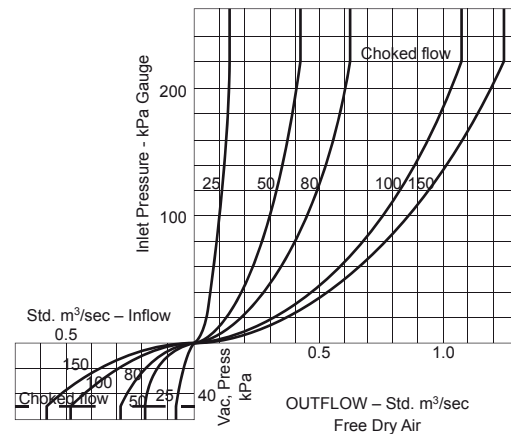

## DIMENSIONS

Valve Dia.	A	C	D	E	Max WP kPa	Approx Wt Kg	Orifice Dia.	Ball Dia.	G BSP
25mm	138	133	115	13	1400	5	25	51	25
50mm	203	153	150	19	1400	9	44	76	50
80mm	248	197	185	19	1400	18	64	100	80