

JOHN FIG. 59 Threaded Gate Valve – 3500 kPa

PRESSURES: 3500 kPa CWP – DN15 to DN25
2500 kPa CWP – DN32 to DN50
Maximum Working Pressure @100 °C

CONNECTIONS: AS1722.2 (BSPP)

STANDARDS: Dezincification Resistant
AS 1628: Copper Alloy Valves
AS 4020: Materials Suitable for Potable Water Service

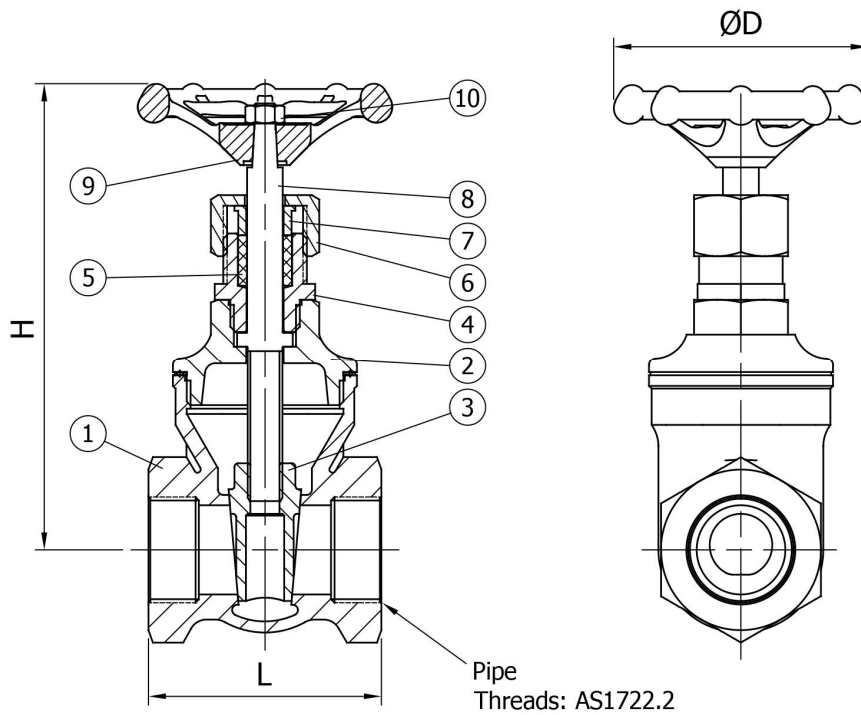

ITEM	DESCRIPTION	MATERIAL	STANDARD
1.	BODY	GUNMETAL	AS1565-C83600
2.	BONNET	GUNMETAL	AS1565-C83600
3.	WEDGE	GUNMETAL	AS1565-C83600
4.	STUFFING BOX	DZR BRASS	AS1567-C35330
5.	PACKING	PTFE	
6.	GLAND NUT	DZR BRASS	AS1567-C35330
7.	GLAND	DZR BRASS	AS1567-C35330
8.	STEM	DZR BRASS	AS1567-C35330
9.	HANDWHEEL	ALUMINIUM	
10.	HANDWHEEL NUT	CS – ZINC PL.	

SIZE	L	H	D	Wt. (kg)
15	60	108	64	0.6
20	60	113	73	0.7
25	67	134	73	1.1
32	76	156	92	1.5
40	86	170	92	2.4
50	96	212	105	3.6