

1 2 3 4 5 6 7 8

A

B

C

D

E

F

A

B

C

D

E

F

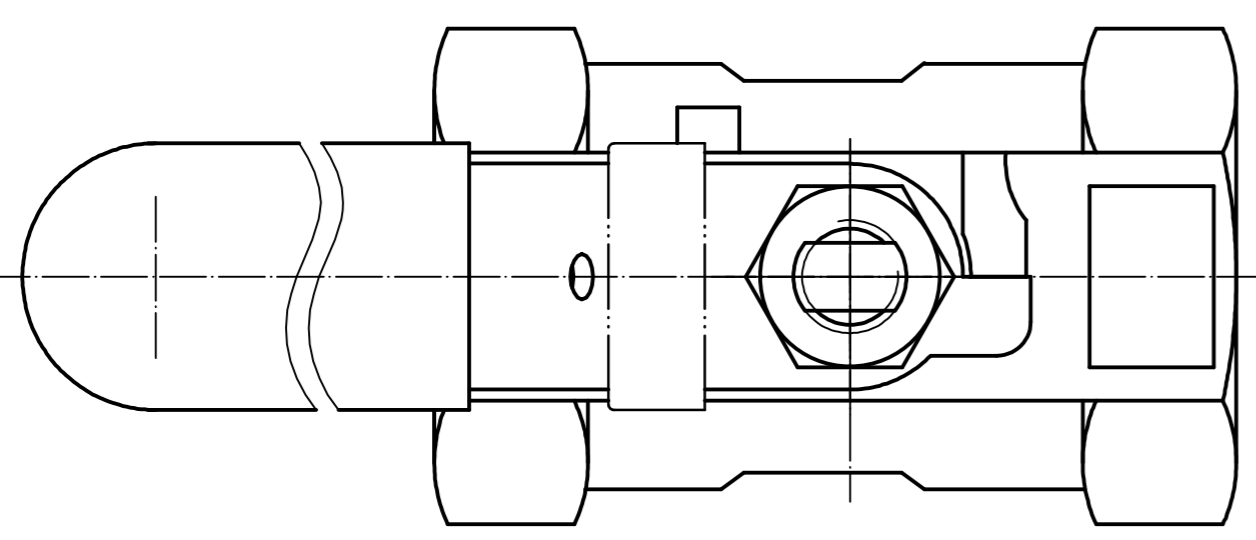
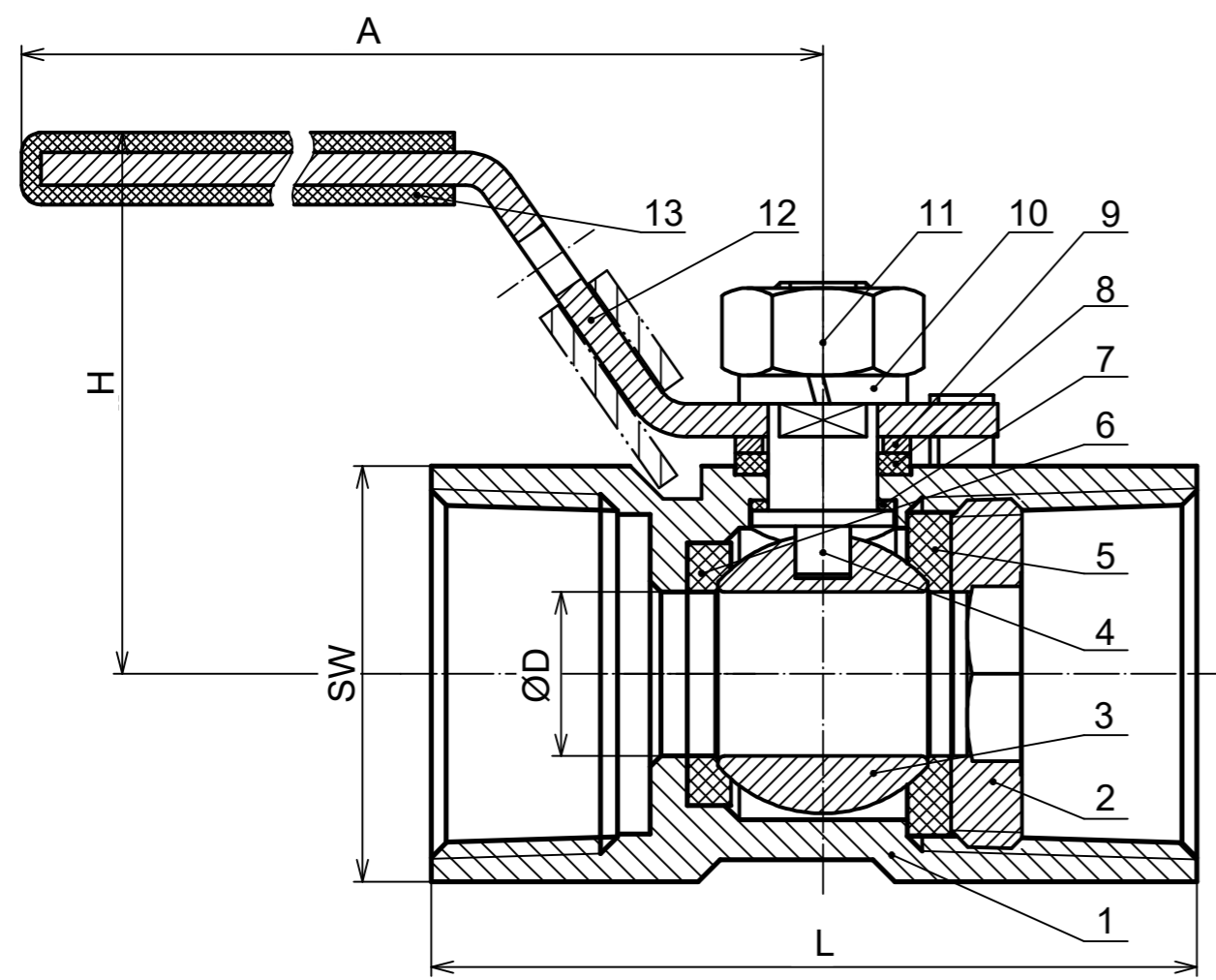

13	SBT-01-XX	HANDLE COVER	1	PVC						
12	SB11-01-XX(SB12-01-XX)	HANDLE	1	SS304						
11	GB/T6172. 1-2000	NUT	1	A2-70						
10	GD-01-XX	SPRING WASHER	1	SS304						
9	GD-01-XX	WASHER	1	SS304						
8	Q118-08	GASKET	1	PTFE						
7	ZD-XX-XX	STEM PACKING	1	PTFE						
6	Q118-06	SEAT	1	PTFE						
5	Q118-05	SEAT	1	PTFE						
4	Q118-04	STEM	1	SS316						
3	QTZS-XX-XX	BALL	1	SS316						
2	Q118-02	CAP	1	SS316						
1	Q118-01	BODY	1	SS316						
	PART NUMBER	DESCRIPTION	QTY	MATERIAL						

SIZE	1/4"	3/8"	1/2"	3/4"	1"	1-1/4"	1-1/2"	2"	2-1/2"	3"
D	5	7	9.2	12.5	15	20	25	32	38	50
L	39±1	44±1	55±1	59±1	69±1	77±1	81±1	97±1.5	127±1.5	153±1.5
H	33	35	40	44	50	57	64	68	85	90
A	71	93	95	95	113	113	141	141	189	189
SW	17	21	24.5	32	37	47.5	53	64.5	82.5	96

**1 PIECE BALL VALVE**

**FIG. 801**

PROJECTION B1

SCALE 1.5:1

# JOHN VALVES

1 2 3 4 5 6 7 8