

JOHN FIG 430

Duo Check Valve

Materials

ITEM	PART	MATERIAL
1	Body	Ductile Iron
2	Disc	ASTM A351 CF8M
3	Stem	AISI 316
4	Spring	AISI 316
4	Seal	EPDM
5	Bushing	Teflon
7	Adjusting Screw	AISI 304

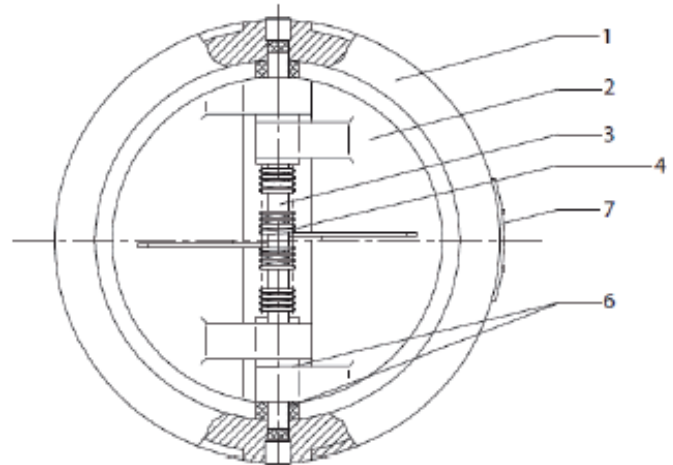

Dimensions (Measurements in mm)

Size	L	D	D1	D2	Weight (Kg)
50	43	98	65	40	1.5
65	46	110	80	60	2.4
80	64	128	94	70	3.6
100	64	156	117	88	5.7
125	70	187	145	115	7.3
150	76	213	170	134	9
200	89	267	224	182	17
250	114	328	265	220	26
300	114	375	310	260	55
350	127	448	360	296	55
400	140	498	410	350	75
450	152	562	450	385	107
500	152	619	505	438	111
600	178	727	624	538	165

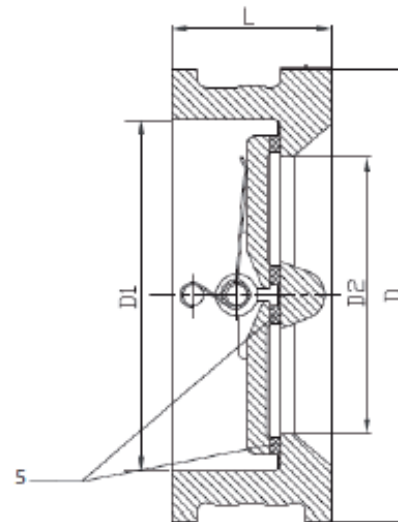

HEAD OFFICE: 19 Martin Drive, Delacombe, VIC, 3356 | (03) 5336 2113
 WA: (08) 9249 1942 NSW: 0447 327 312 | QLD: 0427 784 419 | SA: 0418 503 570
sales@johnvalves.com.au | johnvalves.com.au

John Valves Pty Ltd Reserve the right to change materials and/or dimensions without notice 01/24

JOHN VALVESTM
 The Valve People Since 1896