

Valve Overview

Body Material	Cast Iron
Size Range	DN50-DN300
Pressure Rating	PN16
Coating	FBE
Connections	Flanged Table D

Materials

ITEM	PART	MATERIAL
1	Body	Cast Iron
2	Ball	EPDM
3	Bolt	Stainless Steel
4	Nut	Stainless Steel
5	Gasket	NBR
6	Bonnet	Cast Iron
7	Washer	Nylon
8	Plug	Stainless Steel

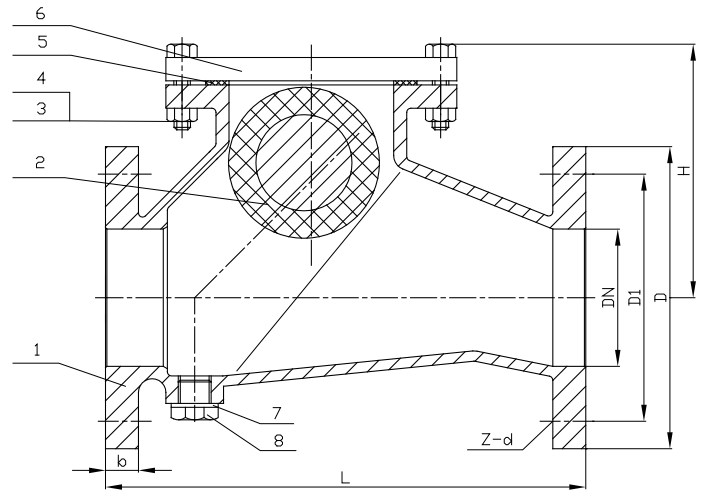

Dimensions (measurements in mm)

Size	L	D	D1	B	Z-d	H
50	200	152.4	114.3	7.9	4-18	135
65	240	165.1	127	7.9	4-18	150
80	260	184.1	146	9.5	4-18	165
100	300	215.9	177.8	9.5	4-18	185
150	400	279.4	234.9	12.7	8-18	234.5
200	500	336.6	22.1	12.7	8-18	285
250	600	406.4	355.6	15.9	8-22	350
300	700	457.2	406.4	19	12-22	420