

JOHN FIG 70

Safety & Relief Valves

The John Fig 70 Safety Relief Valve incorporates a top-guided design with unobstructed seat bores and high lift ability. The bronze valve body can be supplied with resilient trim or metal trim based on requirements. The John Fig 70 is suitable for air/gas, steam/hot water (above 100°C) and liquid applications. For inline checking, test levers and the option of a sealed dome can be supplied for service conditions with the requisite of a pressure-tight seal on the discharge side, e.g., liquid service with enclosed discharge.

Body	Bronze
Trim	Stainless Steel Stainless Steel/EPDM (optional)
Sizes	DN15 - DN50
Pressure Rating	PN24
Temperature	Stainless Steel / EPDM (-20°C – 95°C) Stainless Steel (-20°C - 244°C)
Connections	BSP (MALE) X BSP (FEMALE) Standard BSP (FEMALE) X BSP (FEMALE) Optional
Pressure Range	0.35 to 24 bar
Standards	AS 1271, Class A; wBS6759 Pt 1,2,3; ASME- Boiler and Pressure Vessel Code, Section VIII

Dimensions

Type	Size	Inlet	Outlet	A (mm)	B (mm)	C (mm)	Kg
MALE X FEMALE	DN15	1/2"	3/4"	59	29	130	1
	DN20	3/4"	1-1/4"	65	37	159	1.6
	DN25	1"	1-1/2"	78	40	185	2.1
	DN32	1-1/4"	2"	89	48	205	4
	DN40	1-1/2"	2-1/2"	95	56	245	7
	DN50	2"	3"	109	71	298	10
FEMALE X FEMALE	DN15	1/2"	3/4"	40	29	111	1
	DN20	3/4"	1-1/4"	46	37	140	1.6
	DN25	1"	1-1/2"	56	40	163	2.1
	DN32	1-1/4"	2"	67	48	183	4
	DN40	1-1/2"	2-1/2"	67	56	216	7
	DN50	2"	3"	79	71	268	10

Materials of Construction

ID	PART	MATERIAL	SPECIFICATION
1	Body	Bronze	
2	Seat	Bronze/ Stainless Steel	
3*	Disc	Stainless Steel	
	Optional	EPDM (Resilient Seated)	
4	Spindle	Stainless Steel	
5	Spring cap	Stainless Steel	
p6*	Spring	Chrome Alloy	
7	Adjusting Screw	Bronze	
8	Locking Ring	Bronze	
9	Dome	Bronze	
10	Lever	Bronze	
11*	Ball	Stainless Steel	
12	Padlock	Brass	
13	Bush	PTFE	
14	Pining Screw	Stainless Steel	

* Recommended spares; available from John Valves. Recommended inspection every 12 months.

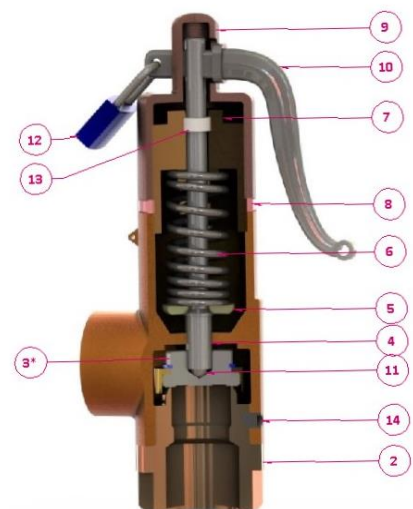
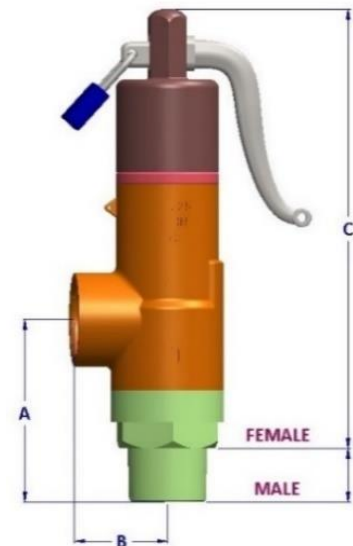

John Valves Pty Ltd Reserve the right to change materials and/or dimensions without notice | 03/2025
 Head Office: 19 Martin Drive, Delacombe, VIC, 3356 | (03) 5336 2113
sales@johnvalves.com.au | johnvalves.com.au



JOHN FIG 70

Safety & Relief Valves

Size Range			
Size	Orifice mm ²	Min (Barg) Pressure	Max (Barg) Pressure
DN15 (1/2")	126	0.3	24.0
DN20 (3/4")	364	0.3	24.0
DN25 (1")	481	0.3	24.0
DN32 (1-1/4")	791	0.3	24.0
DN40 (1-1/2")	1240	0.3	24.0
DN50 (2")	1943	0.3	24.0

Performance		
Size	Over Pressure	Blow Down
Steam	10%	15%*
Hot Water‡	10%	15%*
Air/Gas	10%	15%*
Liquid	10%	15%*

* Or 0.3 Barg min † or 0.6 Barg min ‡ above 100°C

Maximum Back Pressure	
Barg	5.5
Constant	80%
Built-up	10%
Variable	0%

Figure Numbering

END CONNECTION	OPERATOR	BODY MATERIAL	TRIM	PAINTING	BOLTING	TESTING/INSPECTION	SPECIAL FEATURES
B	V	4	2	0	0	3	0
BSP THREADED	SAFETY LEVER, SAFETY VALVE	BRONZE	STAINLESS STEEL			MILL & HYDRO	
	D		2				
	DOME CAP RELIEF VALVE		EPDM			MILL & HYDRO	

AIR CAPACITY CHART [l/s] AT 0.3 Barg or 10% OVERPRESSURE and 15°C

Set Pressure	DN 15	DN 20	DN 25	DN 32	DN 40	DN 50
0.35	3.93	11.4	15	24.7	38.7	60.6
1.0	8.29	23.9	31.6	52	81.5	128
2.0	13.6	39.1	51.7	85.1	133	209
3.0	18.3	52.8	69.8	115	180	282
4.0	22.9	66.3	87.6	144	226	354
5.0	27.6	79.7	105	173	272	426
6.0	32.3	93.2	123	203	318	498
7.0	36.9	107	141	232	363	569
8.0	41.6	120	159	261	409	641
9.0	46.3	134	177	290	455	713
10.0	50.9	147	194	320	501	785
12.0	60.2	174	230	378	593	929
12.5	62.6	181	239	393	616	965
14.0	69.6	201	266	437	684	1073
16.0	78.9	228	301	495	776	1216
18.0	88.2	255	337	554	868	1360
20.0	97.5	282	372	612	960	1504
22.0	107	309	408	671	1051	1648
24.0	116	336	443	729	1143	1791

Other Gases

For application of the valve for other compatible gases, the sizing details above can be used. The valve capacity will change depending on the specific gravity of gas. To calculate the gas capacity, multiply the valve air capacity by $1/\sqrt{SG}$. SG = specific gravity (relative to gas = 1).

Useful Conversions

Nm³/h = 1/sec X 3.60

SCFM = 1/sec X 2.12

*Minimum Overpressure = 0.07 Barg at set pressure less than 1.0 Barg



John Valves Pty Ltd Reserve the right to change materials and/or dimensions without notice | 03/2025

Head Office: 19 Martin Drive, Delacombe, VIC, 3356 | (03) 5336 2113

sales@johnvalves.com.au | johnvalves.com.au



SATURATED STEAM CAPACITY CHART [kg/h]

Set Pressure	DN 15	DN 20	DN 25	DN 32	DN 40	DN 50
0.35	9.68	28	37	60.8	95.3	149
1.0	22.6	65.2	86.2	142	222	348
2.0	35.9	104	137	225	353	553
3.0	47.8	138	182	300	470	737
4.0	59.3	171	226	372	583	914
5.0	76.6	221	292	481	753	1181
6.0	89	257	340	559	876	1372
7.0	99.9	289	381	627	983	1540
8.0	112	324	428	705	1104	1731
9.0	123	355	469	771	1208	1893
10.0	135	390	515	848	1329	2082
12.0	157	454	600	987	1548	2425
12.5	167	482	637	1048	1642	2573
14.0	182	524	693	1140	1787	2799
16.0	210	606	801	1318	2066	3237
18.0	243	702	928	1527	2393	3750
20.0	256	739	977	1606	2518	3946
22.0	284	822	1086	1786	2799	4386
24.0	308	889	1174	1931	3027	4743

Other Temperatures

The above steam table is based on saturated steam. For steam systems operating at higher temperatures, the above capacities will need to be derated by using the super heat correction factor.

Useful Conversions

lbs/h = kg/h X 2.2046

Minimum overpressure = 0.07 Barg at set pressure less than 0.7 Barg.

WATER CAPACITY CHART [l/min] AT 10% OVERPRESSURE AT 20°C

Set Pressure	DN 15	DN 20	DN 25	DN 32	DN 40	DN 50
0.35	10.3	29.8	39.4	64.8	102	159
1.0	16.7	48.3	63.8	105	164	258
2.0	23.6	68.3	90.2	148	233	364
3.0	28.9	83.6	110	182	285	446
4.0	33.4	96.5	128	210	329	515
5.0	37.4	108	143	235	368	576
6.0	40.9	118	156	257	403	631
7.0	44.2	128	169	278	435	682
8.0	47.3	137	180	297	465	729
9.0	50.1	145	191	315	493	773
10.0	52.8	153	202	332	520	815
12.0	57.9	167	221	363	570	893
12.5	59.1	171	226	371	581	911
14.0	62.5	181	239	392	615	964
16.0	66.8	193	255	420	658	1031
18.0	70.9	205	271	445	698	1093
20.0	74.7	216	285	469	735	1152
22.0	78.4	226	299	492	771	1208
24.0	81.9	236	312	514	806	1262

Other Temperatures

The above steam table is based on saturated steam. For steam systems operating at higher temperatures, the above capacities will need to be derated by using the super heat correction factor.

Useful Conversions

lbs/h = kg/h X 2.2046

Minimum overpressure = 0.07 Barg at set pressure less than 0.7 Barg.

Minimum overpressure = 0.07 Barg at set pressure less than 1.0 Barg.



HOT WATER CAPACITY CHART (kW) FOR A PRESSURISED (un-vented) SYSTEM

Set Pressure	DN 15	DN 20	DN 25	DN 32	DN 40	DN 50
0.35	6.88	19.9	26.3	43.2	67.7	106
1.0	14	40.5	53.5	88	138	216
2.0	22.9	66.3	87.5	144	226	354
3.0	30.9	89.4	118	194	304	477
4.0	38.8	112	148	244	382	599
5.0	46.7	135	178	293	460	720
6.0	54.6	158	208	343	537	842
7.0	62.5	181	239	392	615	964
8.0	70.4	203	269	442	693	1085
9.0	78.3	226	299	491	770	1207
10.0	86.2	249	329	541	848	1329
12.0	102	294	389	640	1003	1572
12.5	106	306	404	665	1042	1633
14.0	118	340	449	739	1158	1815
16.0	133	386	510	838	1314	2059
18.0	149	431	570	937	1469	2302
20.0	165	477	630	1036	1624	2545
22.0	181	522	690	1135	1780	2788
24.0	197	568	751	1234	1935	3032

Other Temperatures

The above steam table is based on saturated steam. For steam systems operating at higher temperatures, the above capacities will need to be derated by using the super heat correction factor.

Useful Conversions

lbs/h = kg/h X 2.2046

Minimum overpressure = 0.07 Barg at set pressure less than 0.7 Barg.

Minimum overpressure = 0.07 Barg at set pressure less than 1.0 Barg.