

# JOHN FIG. 1M Globe Valve

**PRESSURES:** 2100 kPa CWP  
Steam: 1200 kPa @ 200°C

**STANDARDS:** Dezincification Resistant  
BS 5154 - 1991: Globe Stop & Check Valves  
AS 4020: Materials suitable for potable Water Services

**Options:** Bronze Handwheels  
Open-Shut Indicators  
Locking Devices

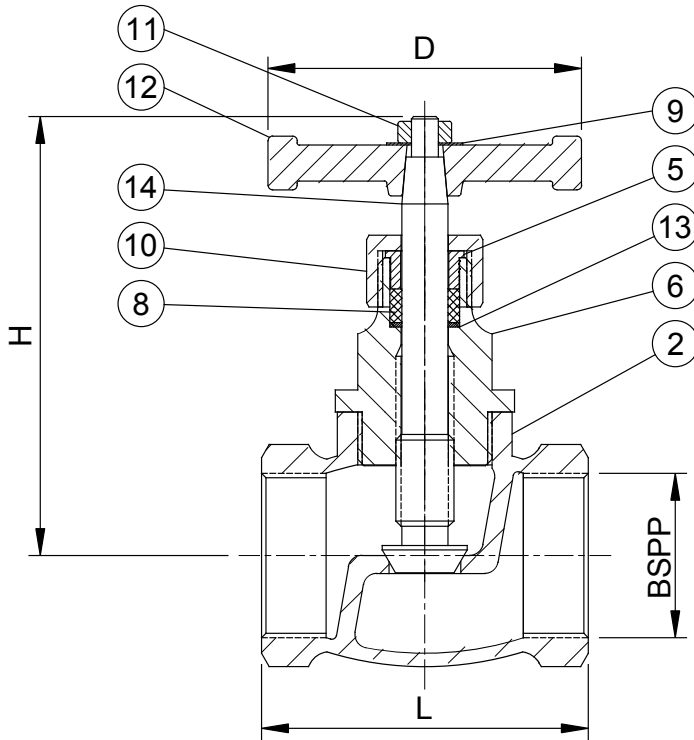

Valve available as  
SDNR - Controllable lift.  
Sizes 25mm - 80mm  
Fig No T1MCL

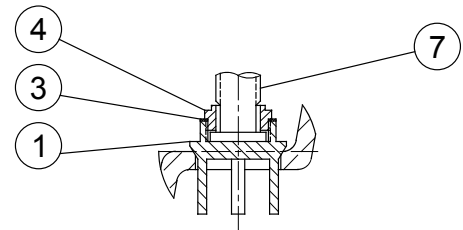

Disc Construction  
32mm - 80mm

## MATERIALS OF CONSTRUCTION

ITEM	DESCRIPTION	MATERIAL	STANDARD
1.	DISC	GUNMETAL BRONZE	AS1565 C83600
2.	BODY	GUNMETAL BRONZE	AS1565 C83600
3.	LOCK WASHER	DR BRASS	AS1567 - 352
4.	DISC NUT	DR BRASS	AS1567 - 352
5.	GLAND	DR BRASS	AS1567 - 352
6.	COVER - BONNET	GUNMETAL BRONZE	AS1565 C83600
7.	SPINDLE	DR BRASS	AS1567 - 352
8.	GLAND PACKING	PTFE	AS1198
9.	NAMEPLATE		
10.	GLAND NUT	DR BRASS	AS1567 - 352
11.	HANDWHEEL NUT	BRASS	
12.	HANDWHEEL	ALUMINIUM	AS1874
13.	SEAL RING	DR BRASS	AS1567 - 352
14.	DISC - SPINDLE	DR BRASS	AS1567 - 352

## DIMENSIONS

SIZE	L	H	D	wt. (kg)
15	56	83	55	0.4
20	59	95	65	0.6
25	73	97	65	0.85
32	87	133	90	1.6
40	92	152	90	2.0
50	114	165	90	3.1
65	143	185	150	4.7
80	165	216	150	6.8

John Valves P/L reserves the right to change materials and/or dimensions without notice.

9/18