

# JOHN FIG. 843WG DN350 - DN600 Gear

1. Design and manufacture according to AS4795.
2. Face to face according to AP1609
3. Flange drilling according to AS2129 Table E.
4. Top flange drilling according to ISO 5211
5. Pressure test according to ISO5208

Nominal pressure PN16  
Test - Strength test 2.4Mpa  
Pressure - Sealing test 1.76Mpa  
Maximum working temperature -10°C to + 90°C  
Suitable Media W.O.G etc

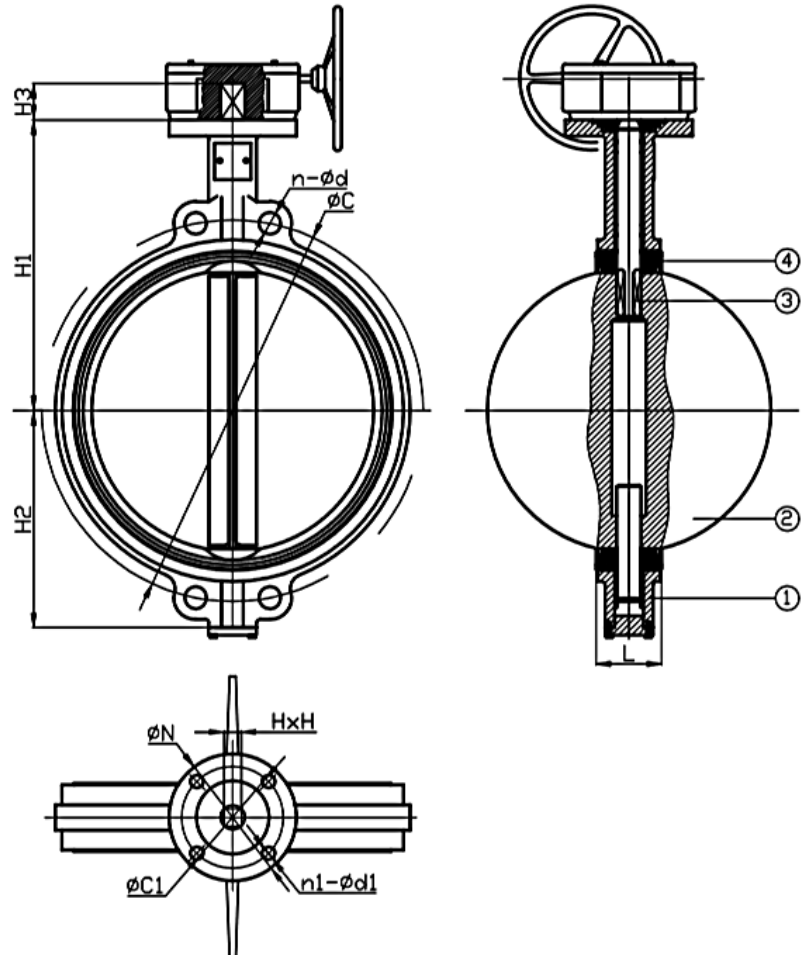

## MATERIALS OF CONSTRUCTION

ITEM	DESCRIPTION	MATERIAL
1.	BODY	DUCTILE IRON
2.	DISC	CF8M
3.	STEM	SS431
4.	SEAT	EPDM

## DIMENSIONS

SIZE	L	AS2129 T/E		H1	H2	H3	ISO5211				H
		ØC	n-Ød				TOP	ØN	ØC1	n1-Ød1	
DN350	78	470	12-26	368	267	45	F10	125	102	4-Ø12	22
DN400	102	521	12-26	400	298.6	51.2	F14	175	140	4-Ø18	27
DN450	114	584	16-26	422	318	51.2	F14	175	140	4-Ø18	27
DN500	127	641	16-26	480	355	64.2	F14	175	140	4-Ø18	36
DN600	154	756	16-33	562	444	70.2	F16	210	165	4-Ø22	36